

Xpert® Xpress Strep A

For use with GeneXpert® System with Touchscreen



Catalog Numbers

REF XPRSTREPA-10

REF XPRSTREPA-120

303-0929 | Rev. B | 2023-11

R_xonly **IVD** *In Vitro* Diagnostic Medical Device

Trademark, Patents and Copyright Statements

Cepheid®, the Cepheid logo, GeneXpert®, and Xpert® are trademarks of Cepheid, registered in the U.S. and other countries.

All other trademarks are the property of their respective owners.

THE PURCHASE OF THIS PRODUCT CONVEYS TO THE BUYER THE NON-TRANSFERABLE RIGHT TO USE IT IN ACCORDANCE WITH THESE INSTRUCTIONS FOR USE. NO OTHER RIGHTS ARE CONVEYED EXPRESSLY, BY IMPLICATION OR BY ESTOPPEL. FURTHERMORE, NO RIGHTS FOR RESALE ARE CONFERRED WITH THE PURCHASE OF THIS PRODUCT.

© 2017–2023 Cepheid.

See Revision History for a description of changes.

Table of Contents

	Getting Started.....	5
	Product Information.....	5
	Proprietary Name.....	5
	Common or Usual Name	5
	Intended Use, Summary, and Principle of Procedure	5
	Intended Use.....	5
	Summary and Explanation.....	5
	Principle of the Procedure.....	6
	Reagents, Instruments, and Materials.....	7
	Reagents	7
	Materials Provided.....	7
	Materials Required but Not Provided	7
	Materials Available but Not Provided.....	8
	Warnings and Precautions	8
	General.....	8
	Specimen	8
	Test/Reagent.....	9
	Chemical Hazards, Storage and Handling	10
	Chemical Hazards.....	10
	Storage and Handling	11
	Specimen Collection, Testing, and Results	12
	Specimen Collection.....	12
	Swab Collection Procedure.....	12
	Specimen Transport and Storage.....	14
	Procedure	14
	Preparing the Cartridge	14
	Starting the Test: GeneXpert System with Touchscreen.....	17
	Viewing Results in Cepheid OS 2.1 or Higher	19
	Quality Control	19
	External Controls	19
	Results.....	19
	Reasons to Repeat the Test	20
	Retest Procedure	21
	Limitations	21
	Limitations of the Procedure	21
	Expected Values	22
	Specific Performance Characteristics	23

Clinical Performance	23
Analytical Performance.....	24
Analytical Sensitivity (Limit of Detection)	24
Analytical Reactivity (Inclusivity)	25
Analytical Specificity (Exclusivity).....	26
Carry-over Contamination.....	28
Potentially Interfering Substances.....	28
Microbial Interference	29
Reproducibility	29

 Appendix.....	31
Bibliography.....	31
Cepheid Headquarters Locations	31
Technical Assistance.....	32
Table of Symbols	32
Revision History.....	33



Getting Started

Product Information

Proprietary Name

Xpert® Xpress Strep A

Common or Usual Name

Xpert Xpress Strep A

Intended Use, Summary, and Principle of Procedure

Intended Use

The Xpert Xpress Strep A test, performed on the GeneXpert® Instrument Systems, is a rapid, qualitative *in vitro* diagnostic test for the detection of *Streptococcus pyogenes* (Group A β -hemolytic *Streptococcus*, Strep A) in throat swab specimens from patients with signs and symptoms of pharyngitis. The Xpert Xpress Strep A test can be used as an aid in the diagnosis of Group A Streptococcal pharyngitis. The test is not intended to monitor treatment for Group A *Streptococcus* infections.

The Xpert Xpress Strep A test utilizes an automated real-time polymerase chain reaction (PCR) to detect *Streptococcus pyogenes* DNA.

Summary and Explanation

Group A streptococci are gram-positive, beta-hemolytic bacterial pathogens that commonly cause infections in the throat (pharyngitis or “strep throat”) or on skin (cellulitis and impetigo), and can cause a wide range of other infections (e.g., sepsis, pneumonia, and meningitis). Pharyngitis may also be caused by other bacteria including *Neisseria gonorrhoeae* and *Corynebacterium diphtheriae*, for which specific culture methods are required. If left untreated, mild infections can lead to more serious infections. The most severe but least common forms of invasive Group A streptococcal disease are necrotizing fasciitis and streptococcal toxic shock syndrome (STSS). Approximately 9,000 to 11,500 cases of invasive Group A streptococcal (GAS) disease occur annually in the United States, resulting in 1,000 to 1,800 deaths, although several million cases of strep



throat and impetigo occur each year.¹ Treating an infected person with an appropriate antibiotic generally prevents the spread of the infection and reduces the risk of post-infectious complications, such as rheumatic fever and acute glomerular nephritis.²

The Xpert Xpress Strep A test is a rapid PCR test for the qualitative detection of Group A streptococci from throat swab specimens without the need for culture confirmation of negative Xpert Xpress Strep A results. For negative samples, the time to result is 24 minutes. For positive samples, the time to result can be as early as 18 minutes.

Principle of the Procedure

The test is performed on the Cepheid GeneXpert Instrument Systems. With this platform, the operator can run the test by performing three simple steps: 1) transfer liquid sample to the cartridge with a transfer pipette, 2) run the test on the GeneXpert instrument, and 3) read the results. The GeneXpert automates and integrates sample preparation, nucleic acid extraction, amplification, and detection of the target sequences in clinical specimens by using real-time PCR. The system consists of a GeneXpert instrument, computer, and disposable fluidic cartridges that are designed to complete sample preparation and real-time PCR. The system requires the use of single-use disposable GeneXpert cartridges that hold the PCR reagents and host the PCR processes. Because the cartridges are self-contained, the risk of cross-contamination between samples is minimized.

The Xpert Xpress Strep A test includes reagents for the detection of Group A streptococcal bacterial DNA from throat swab specimens obtained from patients with signs and symptoms of pharyngitis. A Sample Processing Control (SPC) and a Probe Check Control (PCC) are also included in the cartridge. The SPC is present to control for an adequate amplification process and to monitor for the presence of inhibitors in the PCR reaction. The PCC verifies reagent rehydration, PCR tube filling, and all reaction components, including probes and dyes, are present and functional in the cartridge.

An Early Assay Termination function provides positive results if the signal from the target DNA reaches a predetermined threshold before the full 43 PCR cycles have been completed. When the Strep A target level is high enough to generate very early Cts (≤ 30 Cts), the SPC amplification curve will be not seen and its results will not be reported as the SPC Ct may not reach the expected cycle threshold in high Strep A titer specimens.

Reagents, Instruments, and Materials

Reagents

Materials Provided

The Xpert Xpress Strep A kit (XPRSTREPA-10) contains sufficient reagents to process 10 specimens or quality control samples and the Xpert Xpress Strep A kit (XPRSTREPA-120) contains sufficient reagents to process 120 specimens or quality control samples.

Each kit contains the following:

Xpert Xpress Strep A Cartridges with Integrated Reaction Tubes	10 per kit	120 per kit
Bead 1, Bead 2, Bead 3 (freeze-dried)	1 of each per cartridge	1 of each per cartridge
Lysis Reagent (Guanidinium Thiocyanate)	1.5 mL per cartridge	1.5 mL per cartridge
Sodium Hydroxide	1.5 mL per cartridge	1.5 mL per cartridge
Elution Reagent	2.0 mL per cartridge	2.0 mL per cartridge
Disposable Transfer Pipettes	12 per kit	144 per kit
Instructions for Use (Package Insert) (For use with the GeneXpert Xpress System only)	1 per kit	1 per kit
Quick Reference Instructions (For use with the GeneXpert Xpress System only)	2 per kit	2 per kit
CD	1 per kit	1 per kit

- Assay Definition File (ADF)
- Instructions to import ADF into GeneXpert software
- Instructions for Use (Package Insert)

Note Safety Data Sheets (SDS) are available at www.cepheid.com or www.cepheidinternational.com under the **SUPPORT** tab.

Note The bovine serum albumin (BSA) in the beads within this product was produced and manufactured exclusively from bovine plasma sourced in the United States. No ruminant protein or other animal protein was fed to the animals; the animals passed ante- and post-mortem testing. During processing, there was no mixing of the material with other animal materials.

Materials Required but Not Provided



- Copan Liquid Amies Elution Swab (ESwab™) Collection and Transport System. Any of the following ESwab collection kits may be used:
 - Copan 480C with 50 kits per shelf pack, white capture cap collection kit
 - Copan 480CE with 50 kits per shelf pack, pink capture cap collection kit
 - Copan catalog number 480CFA with 50 kits per shelf pack; purple non-capture cap collection kit
- GeneXpert system with touchscreen: GeneXpert instrument, touchscreen unit with built-in scanner, Cepheid OS software version 2.0 or higher, and operator manual.
- Printer: If a printer is required, contact Cepheid Customer Support to arrange for the purchase of a recommended printer.

Materials Available but Not Provided

- NATtrol™ Strep A negative control, ZeptoMetrix® Corporation catalog number NATSDG-6MC (inactivated *Streptococcus dysgalactiae* cells)
- NATtrol Strep A positive control, ZeptoMetrix Corporation catalog number NATSPY-6MC (inactivated *Streptococcus pyogenes* cells)

Warnings and Precautions

General

- For *in vitro* diagnostic use. 
- Treat all biological specimens, including used cartridges, as if capable of transmitting infectious agents. All biological specimens should be handled using standard precautions. Guidelines for specimen handling are available from the U.S. Centers for Disease Control and Prevention³ and the Clinical and Laboratory Standards Institute.⁴
- Follow safety procedures set by your institution for working with chemicals and handling biological samples.
- Performance characteristics of this test have been established with the specimen type listed in [Intended Use](#), Intended Use only. The performance of this test with other specimen types or samples has not been evaluated.
- Reliable results are dependent on adequate specimen collection, transport, storage and processing. Incorrect test results may occur from improper specimen collection, handling or storage, technical error, sample mix-up or because the number of organisms in the specimen is below the limit of detection of the test. Careful compliance with the IFU instructions and the *GeneXpert System Operator Manual* are necessary to avoid erroneous results.
- Performing the Xpert Xpress Strep A test outside the recommended storage temperature ranges and time may produce erroneous or invalid results.

Specimen

- For collection and transport of throat swab specimens, use the ESwab collection kit.
- Throat swab specimens must be collected and tested before the printed expiration date on the ESwab collection kit label.
- Maintain proper storage conditions during specimen transport to ensure the integrity of the specimen (see



[Specimen Collection](#), Specimen Collection, Transport, and Storage). Specimen stability under shipping conditions other than those recommended has not been evaluated.

- Do not freeze ESwab specimens.
- Proper sample collection, storage, and transport are essential for correct results.

Test/Reagent

- Do not open the Xpert Xpress Strep A cartridge lid except when adding specimen.
- Do not use a cartridge that has been dropped after removing it from the packaging.

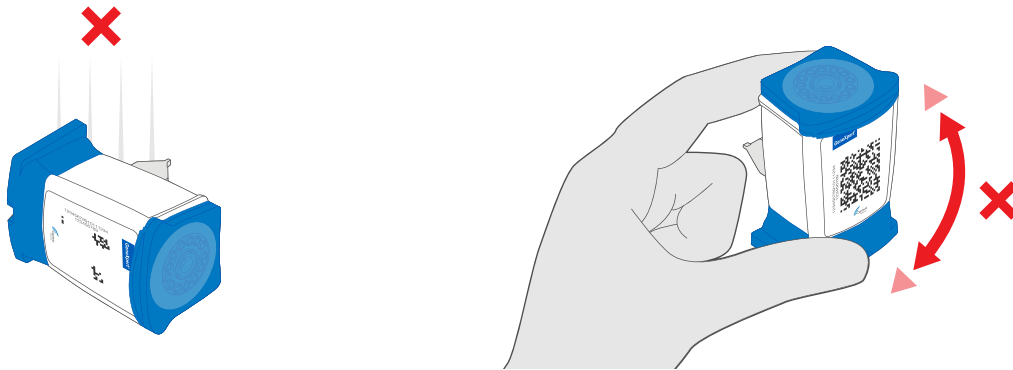

- Do not shake the cartridge. Shaking or dropping the cartridge after opening the cartridge lid may yield invalid results.
- Do not place the sample ID label on the cartridge lid or on the barcode label of the cartridge.



- Do not use a cartridge with a damaged barcode label.
- Hold the cartridge at the base. Do not touch the reaction tube at the rear of the cartridge, as this could cause damage that would interfere with light passing through it during a test. Do not use a cartridge that has a damaged reaction tube.

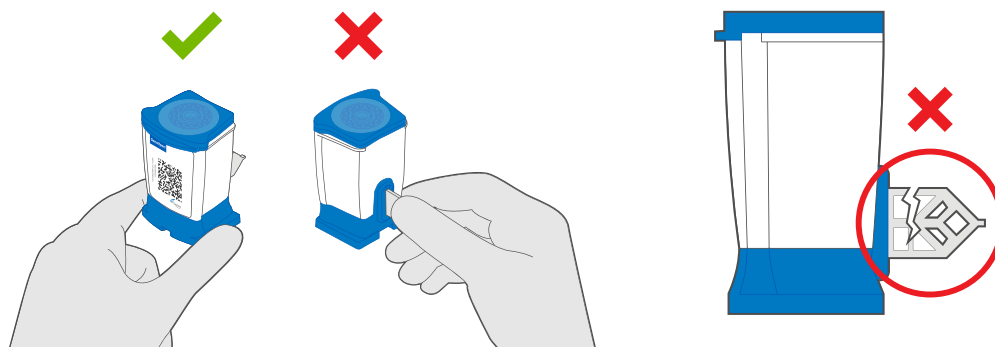



- It is recommended that the Xpert Xpress Strep A cartridges be at room temperature (20 – 30°C) when used for testing.
- Each single-use Xpert Xpress Strep A cartridge is used to process one test. Do not reuse processed cartridges.
- Each single-use disposable pipette is used to transfer one specimen. Do not reuse disposable pipettes.
- Do not use a cartridge if it appears wet or if the lid seal appears to have been broken.
- Wear clean lab coats and gloves. Change gloves between the handling of each specimen.
- In the event of contamination of the work area or equipment with samples or controls, thoroughly clean the contaminated area with a 1:10 dilution of household chlorine bleach and then repeat the cleaning of the work area with 70% denatured ethanol. Wipe work surfaces and allow to dry completely before proceeding.
- Biological specimens, transfer devices, and used cartridges should be considered capable of transmitting infectious agents requiring standard precautions. Follow your institution's environmental waste procedures for proper disposal of used cartridges and unused reagents. These materials may exhibit characteristics of chemical hazardous waste requiring specific disposal. If country or regional regulations do not provide clear direction on proper disposal, biological specimens and used cartridges should be disposed per WHO [World Health Organization] medical waste handling and disposal guidelines.

Chemical Hazards, Storage and Handling

Chemical Hazards^{5,6}

Sodium Hydroxide

- Signal Word: WARNING

Lysis Reagent

- Contains Guanidinium Thiocyanate

- Signal Word: WARNING

- **UN GHS Hazard Statements:**

- Harmful if swallowed.
- Causes skin irritation.
- Causes serious eye irritation.

- **UN GHS Precautionary Statements:**

- **Prevention**

- Wash thoroughly after handling.
- Wear protective gloves/protective clothing/eye protection/face protection.

- **Response**

- IF ON SKIN: Wash with plenty of soap and water.
- Specific treatment, see supplemental first aid information.
- Take off contaminated clothing and wash before reuse.
- If skin irritation occurs: Get medical advice/attention.
- IF IN EYES: Rinse cautiously with water for several minutes. Remove contact lenses, if present and easy to do. Continue rinsing.



- If eye irritation persists: Get medical advice/attention.

Storage and Handling

- Store the Xpert Xpress Strep A cartridges at 2–28 °C until the expiration date provided on the label.
- Do not open the cartridge lid until you are ready to perform testing.
- Do not use cartridges that have passed the expiration date.
- Do not use a cartridge that is wet or has leaked.

① Specimen Collection, Testing, and Results

Specimen Collection

Proper specimen collection, storage and transport are critical to ensure the integrity of the specimen and performance of the test. Inadequate specimen collection, improper specimen handling and/or transport may yield incorrect results. Follow your institution's guidelines for collecting swab specimens using a recommended collection and transport device (see Section 8, Materials Required but Not Provided) and/or follow the instructions below.

Swab Collection Procedure

1. Use the ESwab Collection and Transport System. Remove the swab from the wrapper.

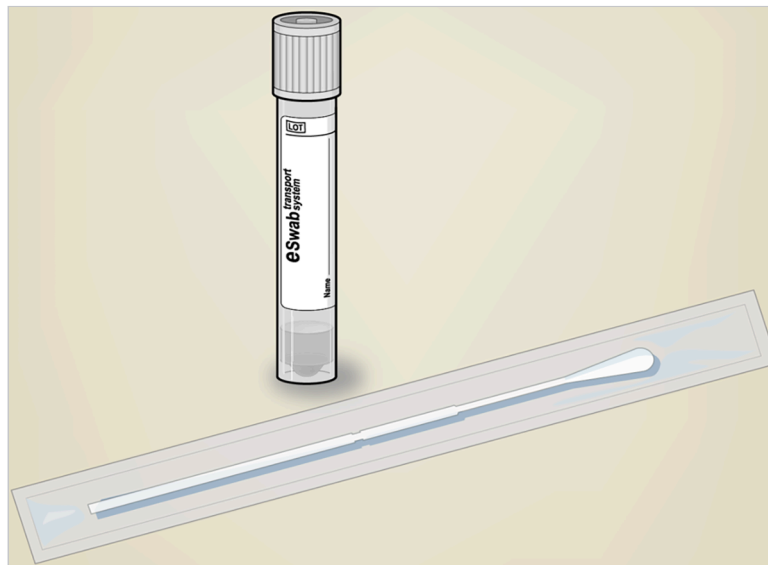

2. Swab the posterior pharynx, tonsils, and other inflamed areas. Avoid touching the tongue, cheeks, and teeth with the swab when collecting specimens.

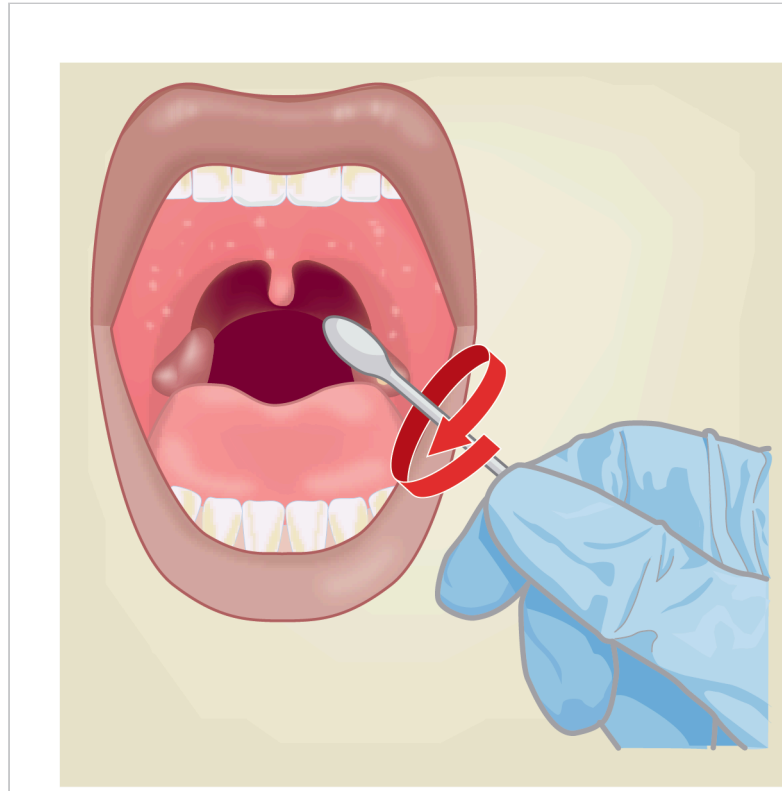

3. Uncap the ESwab transport tube.
4. Place the specimen containing swab into the ESwab transport tube and break the swab at the indicated score line.

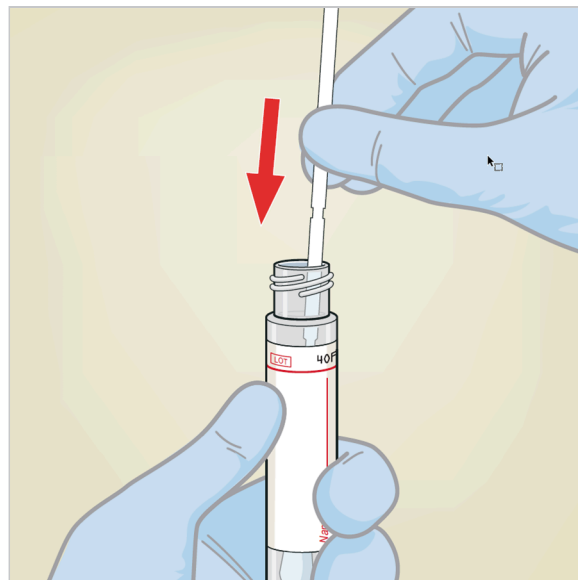

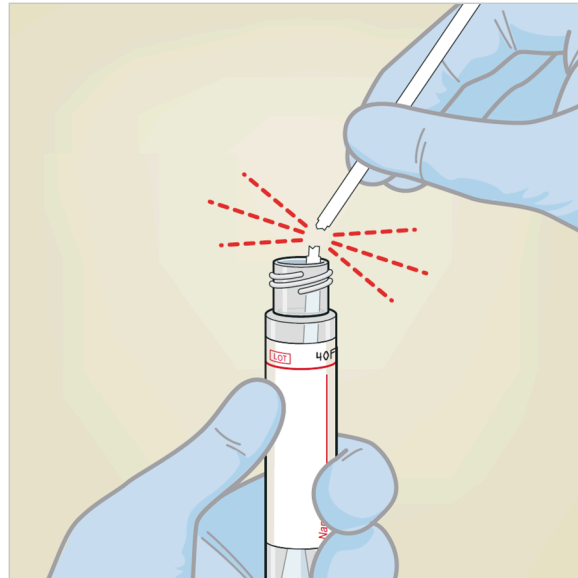

5. Cap the ESwab transport tube.

Note Do not place multiple swabs in the same ESwab transport tube.

Note To reduce the potential for false negative results, do not collect throat swab specimens immediately after patients have used antiseptic mouthwash.

Specimen Transport and Storage

Specimen stability under shipping and storage conditions other than those listed in [Table 1](#) have not been evaluated with the Xpert Xpress Strep A test.

Table 1. Specimen Transport and Storage Conditions

Specimen Collection Device	Specimen Transport and Storage Temperature (°C)	Specimen Storage Time
ESwab (Copan 480C or Copan 480CE or Copan 480CFA)	15-30 °C	Up to 48 hours
	2-8 °C	Up to 6 days

Procedure

Preparing the Cartridge

i Important Start test within 30 minutes of adding the sample to the cartridge.

To add the specimen to the GeneXpert cartridge:

1. Obtain the following items: Xpert Xpress Strep A cartridge, 300 µL transfer pipette (provided), and an appropriately collected and labeled test sample.
2. Inspect the test cartridge for damage. If damaged, do not use it.
3. Mix the patient specimen by vigorously shaking the specimen transport tube for 5 seconds.
4. Open the cartridge by lifting the cartridge lid.



5. Unscrew the specimen transport tube cap (do not remove the cap). Remove the transfer pipette from the wrapper by opening the end next to the bulb. Follow the steps below in Option 1 or Option 2 according to the transfer pipette type included in the kit.

Note Do not place unwrapped pipette on the workbench.

Pipette Option 1:

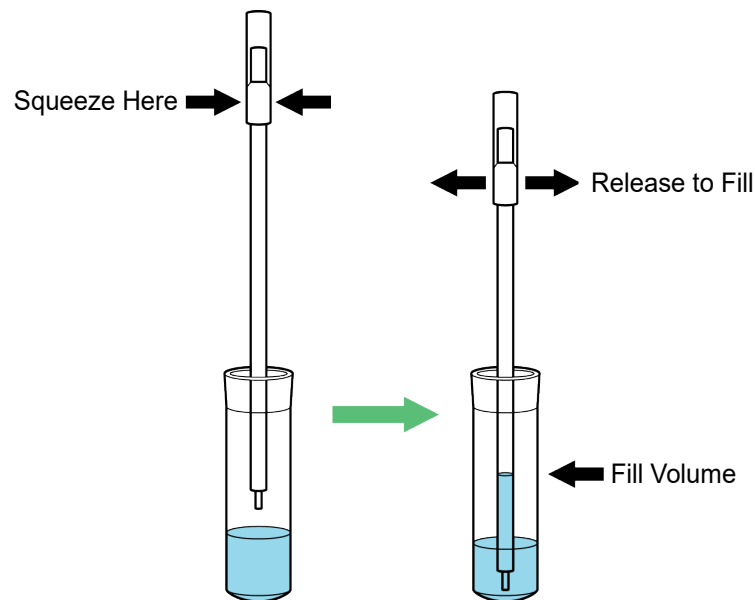

Figure 1 Transfer Pipette

1. Open the cap on the specimen transport tube. Squeeze the bulb of the transfer pipette **completely** and place the pipette tip in the ESwab transport medium tube containing the patient specimen (see [Figure 1](#)). **Note** If using Copan collection kit 480C or 480CE, lift the cap with the attached swab from the transport tube (do not remove the swab completely from the transport tube).
2. Release the bulb of the pipette to fill the pipette with the patient specimen. Check that the pipette does not contain bubbles.
3. To transfer the patient specimen to the cartridge, squeeze the bulb of the transfer pipette completely again to empty the contents of the pipette into the large opening (Sample Chamber) in the cartridge shown in [Figure 2](#).



Figure 2 Cartridge (Top View)

Note Take care to dispense the **entire** volume of liquid into the sample chamber. False negative or **INVALID** results may occur if insufficient sample is added to the cartridge.

4. Close the cartridge lid.
5. Dispose of the used pipette in an appropriate waste container.

Pipette Option 2:

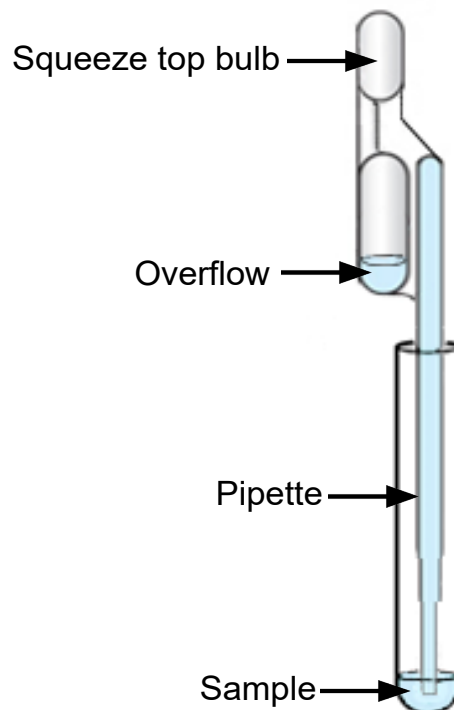

Figure 3 Transfer Pipette

1. Open the cap on the specimen transport tube. Squeeze the top bulb of the transfer pipette **completely**



and place the pipette tip in the ESwab transport medium tube containing the patient specimen (see [Figure 3](#)).

Note If using Copan collection kit 480C or 480CE, lift the cap with the attached swab from the transport tube (do not remove the swab completely from the transport tube).

2. Release the bulb of the pipette to fill the pipette with the patient specimen. Check that the pipette does not contain bubbles.
3. To transfer the patient specimen to the cartridge, squeeze the top bulb of the transfer pipette completely again to empty the contents of the pipette into the large opening (Sample Chamber) in the cartridge shown in [Figure 4](#). It is okay to have excess specimen left in the overflow reservoir of the pipette ([Figure 3](#)).



Figure 4 Cartridge (Top View)

Note Take care to dispense the **entire** volume of liquid into the sample chamber. False negative or **INVALID** results may occur if insufficient sample is added to the cartridge.

4. Close the cartridge lid.
5. Dispose of the used pipette in an appropriate waste container.

Starting the Test: GeneXpert System with Touchscreen

i **Important** Before you start the test, make sure that:

- The system is running the correct Cepheid OS software version shown in section - **Materials Required but Not Provided**.
- The correct assay definition file is imported into the software.

Note The default workflow is shown. Your system administrator may alter the workflow.

1. Turn on GeneXpert system with touchscreen.
2. Log on to system software using your username and password.
3. On the Modules tab, touch **Start Test**.
4. Follow onscreen prompts to create new test and enter patient and sample information.
5. Scan or manually input the cartridge serial number. If scanning, hold the cartridge about 1-3 inches (3-7 cm) away from the scanner. The scanner projects a green crosshair, which you center on the barcode. Scanning is complete when you hear an audible beep. Touch **Continue**.

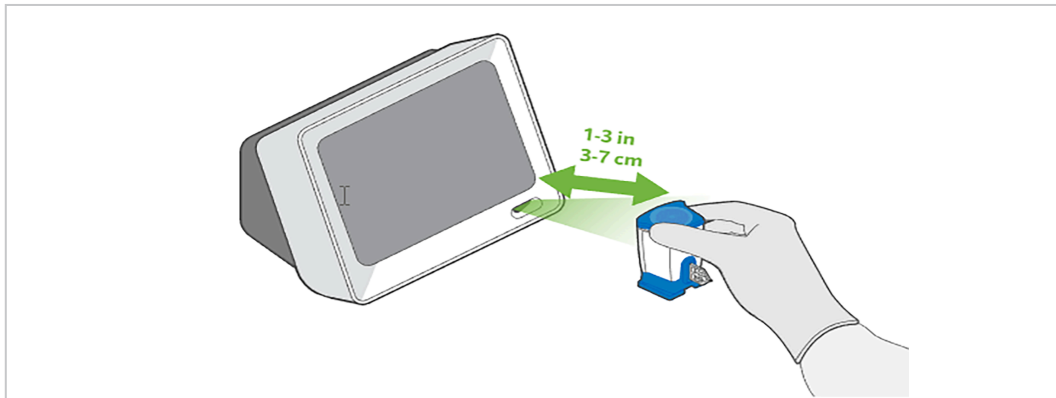

6. Select the desired test and touch **Continue**.
7. Watch the cartridge preparation video, if needed.
8. On the Confirm screen, review all data and touch **Confirm**.
9. Open the module door under flashing green light and insert the cartridge.

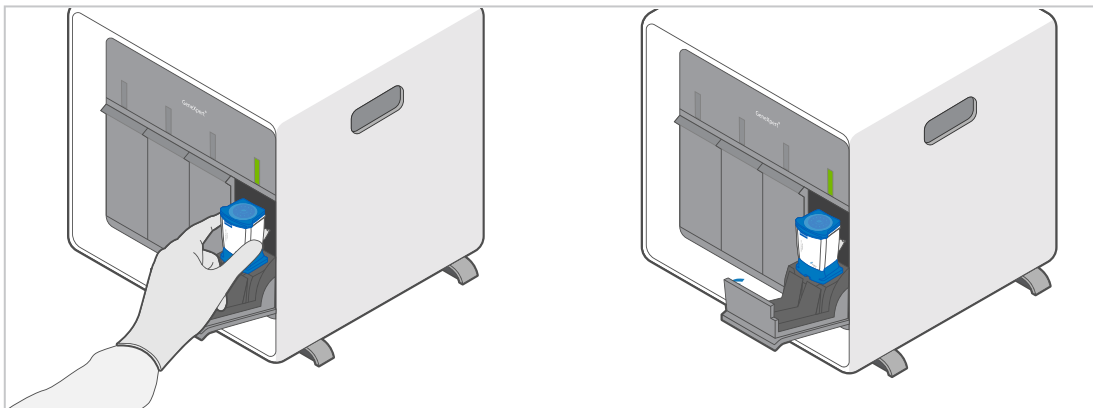

10. Close cartridge module door completely by pressing until it latches. The test starts.

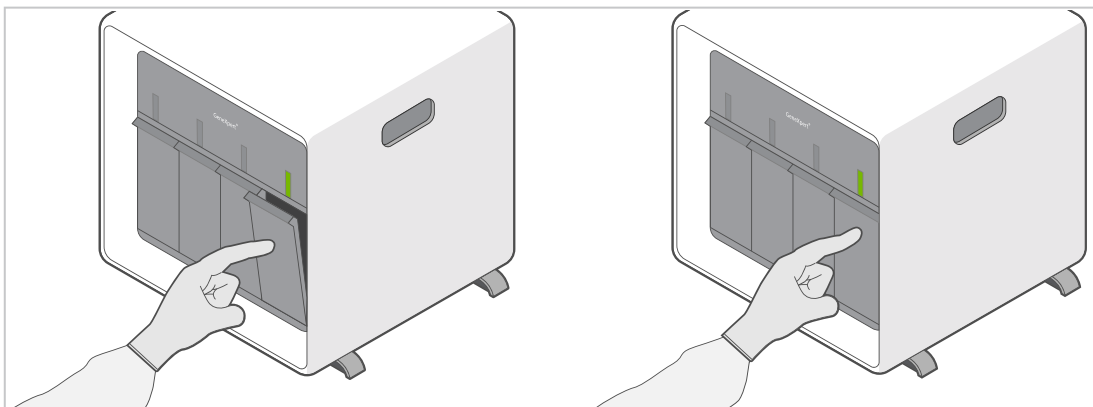

11. When the test completes, the **Results Summary** screen appears. Open the module door and remove cartridge.
12. Dispose of used cartridge in appropriate waste container according to your institution's standard practices.



Viewing Results in Cepheid OS 2.1 or Higher

The Cepheid OS 2.1 results screen will automatically interpret test results for you and clearly show them in the **View Results** window.

1. Tap **Results**.
2. Tap the test to be viewed in the Results screen.
3. Click **OK**.
4. To generate a PDF report file, touch **View Report**. More detailed instructions for viewing and uploading results are available in your system operator manual.

Quality Control

Each cartridge includes a Sample Processing Control (SPC) and Probe Check Control (PCC).

- **Sample Processing Control (SPC):** Ensures the sample was processed correctly. The SPC verifies that sample processing is adequate. Additionally, this control detects sample-associated inhibition of the real-time PCR test, ensures the PCR reaction conditions (temperature and time) are appropriate for the amplification reaction, and that the PCR reagents are functional. The SPC should be positive in a negative sample and can be negative or positive in a positive sample. The SPC passes if it meets the assigned acceptance criteria.
- **Probe Check Control (PCC):** Before the start of the PCR reaction, the GeneXpert Instrument measures the fluorescence signal from the probes to monitor bead rehydration, reaction tube filling, probe integrity, and dye stability. The PCC passes if it meets the assigned acceptance criteria.
- **External Controls:** External controls may be used in accordance with local, state, federal accrediting organizations, as applicable.

External Controls

External controls described in [Materials Available but Not Provided](#) are available but not provided and may be used in accordance with local, state, and federal accrediting organizations, as applicable.

To run a control using the Xpert Xpress Strep A test, perform the following steps:

1. Shake NATtrol sample vigorously for 5 seconds.
2. Open the cartridge lid. Using a clean 300 μ L transfer pipette, transfer 300 μ L (one draw) of the NATtrol sample to the sample chamber with large opening in the cartridge (). Refer to the instructions for the pipette included in the kit.
3. Close cartridge lid.

Results

The results are interpreted automatically by the GeneXpert Instrument Systems and are shown in the View Results window. The possible results and interpretations are shown in [Table 2](#).

**Table 2. Xpert Xpress Strep A Results and Interpretations**

Result	Interpretation
Strep A NOT DETECTED	<p>Strep A target DNA is not detected.</p> <ul style="list-style-type: none"> • SPC: PASS; SPC has a Ct within the valid range and endpoint above the threshold setting. • PCC: PASS; all probe check results pass.
Strep A DETECTED	<p>Strep A target DNA is detected.</p> <ul style="list-style-type: none"> • Strep A: Ct is within the valid range. • SPC: NA (not applicable); SPC signal is not part of the result interpretation algorithm if Strep A is detected since SPC signal may be suppressed due to competition with Strep A. • PCC: PASS; all probe check results pass.
INVALID	<p>Presence or absence of the target DNA cannot be determined.</p> <ul style="list-style-type: none"> • Strep A: INVALID • SPC: does not meet acceptance criteria. • PCC: PASS; all probe check results pass. <p>Repeat test according to the instructions in Retest Procedure, Retest Procedure below.</p>
ERROR	<p>Presence or absence of Strep target DNA cannot be determined.</p> <ul style="list-style-type: none"> • Strep A: NO RESULT • SPC: NO RESULT • PCC: FAIL*; all or one of the probe check results fail. <p>*If the probe check passed or shows NA, the error is caused by the maximum pressure limit exceeding the acceptable range or by a system component failure. Repeat test according to the instructions in Retest Procedure, Retest Procedure below.</p>
NO RESULT	<p>Presence or absence of Strep A target DNA cannot be determined. A NO RESULT indicates that insufficient data were collected. For example, cartridge integrity test failed, the operator stopped a test that was in progress or a power failure occurred.</p> <ul style="list-style-type: none"> • Strep A: NO RESULT • SPC: NO RESULT • PCC: NA (not applicable)* <p>* If the probe check shows NA, the error caused by the maximum pressure limit exceeding the acceptable range terminates the run prior to probe check. Repeat test according to the instructions in Retest Procedure, Retest Procedure below.</p>

Reasons to Repeat the Test

If any of the test results mentioned below occur, repeat the test once according to the instructions in [Retest Procedure](#), Retest Procedure.

- An **INVALID** result indicates that the control SPC failed. The sample was not properly processed, PCR is inhibited, or the sample was not properly collected.
- An **ERROR** result could be due to, but not limited to, Probe Check Control failure, system component failure, or the maximum pressure limits were exceeded.
- A **NO RESULT** indicates that insufficient data were collected. For example, cartridge failed integrity test, the operator stopped a test that was in progress, or a power failure occurred.
- If an External Control fails to perform as expected, repeat external control test and/or contact Cepheid for assistance.



Retest Procedure

1. To retest an **INVALID**, **NO RESULT**, or **ERROR** result (indeterminate result), use a new cartridge.
Use the leftover sample from the original ESwab transport medium tube.
2. Mix the leftover patient specimen by vigorously shaking the specimen transport tube for 5 seconds.
3. Open the cartridge by lifting the cartridge lid.
4. Unscrew the specimen transport tube cap (do not remove the cap). Remove the transfer pipette from the wrapper by opening the end next to the bulb.
5. Lift the cap with the attached swab from the transport tube (do not remove the swab completely from the transport tube). Squeeze the bulb of the transfer pipette completely and place the pipette tip in the ESwab transport medium tube containing the patient specimen ().
6. Release the bulb of the pipette to fill the pipette with the patient specimen.
7. To transfer the patient specimen to the cartridge, squeeze the bulb of the transfer pipette completely again to empty the contents of the pipette into the large opening (Sample Chamber) shown in Figure 2.
8. Close the cartridge lid.
9. Dispose of the used pipette in an appropriate waste container.

Limitations

Limitations of the Procedure

- Additional follow-up testing by culture is required if the Xpert Xpress Strep A test result is negative and clinical symptoms persist, or there is an outbreak of acute rheumatic fever (ARF).
- The performance of the Xpert Xpress Strep A test was evaluated using the procedures provided in this IFU only. Modifications to these procedures may alter the performance of the test.
- Careful compliance with the instructions in this IFU and in the Copan Liquid Amies Elution Swab (ESwab) Collection and Transport System IFU is necessary to avoid erroneous results.
- The Xpert Xpress Strep A test has been validated only with Copan Liquid Amies Elution Swab (ESwab) Collection Kit (Copan 480C or Copan 480CE or Copan 480CFA).
- Because the detection of *Streptococcus pyogenes* is dependent on the organism's DNA present in the sample, reliable results are dependent on proper sample collection, handling, and storage.
- The Xpert Xpress Strep A test provides qualitative results and does not provide the quantitative value of the organism detected in the specimen.
- Mutations or nucleotide polymorphisms in primer or probe binding regions may affect detection of new or unknown *Streptococcus pyogenes* strains resulting in a false negative result.
- A negative test result does not exclude the possibility of infection because the test result may be affected by improper specimen collection, technical error, sample mix-up, or because the number of organisms in the sample is below the limit of detection of the test.
- As with many diagnostic tests, negative results from the Xpert Xpress Strep A test do not preclude a Strep A infection and should not be used as the sole basis for treatment or other patient management decisions. The Xpert Xpress Strep A test does not differentiate asymptomatic carriers of Group A streptococci from those exhibiting streptococcal infection. The results from the Xpert Xpress Strep A test should be interpreted in conjunction with other laboratory and clinical data available to the clinician.
- This test has not been evaluated for patients without signs and symptoms of pharyngitis.



- This test cannot rule out pharyngitis caused by other bacterial or viral pathogens besides Group A streptococci.
- Cross-reactivity with organisms other than those listed in the Exclusivity Table, [Table 8](#) may lead to erroneous results.
- The analyte target (bacterial nucleic acid) may persist in vivo, independent of pathogen viability. Detection of the analyte target does not imply that the corresponding pathogen is infectious, or is the causative agent of the clinical symptoms.

Expected Values

In multi-center clinical studies for the Xpert Xpress Strep A, 577 throat swab specimens were analyzed. Of the 577 specimens, 326 (56.5%) were collected from female subjects and 251 (43.5%) from male subjects. The distribution by age range, along with the number and percentage of cases positive for Strep A, as determined by the Xpert Xpress Strep A, are shown in [Table 3](#).

Table 3. Number and Percent of Specimen by Age Range

Age Range	N	% of Total	Number of Positives	Positivity
0-1 year	3	0.5%	0	0%
2-5 years	76	13.2%	28	36.8%
6-12 years	189	32.8%	80	42.3%
13-21 years	129	22.4%	25	19.4%
22-65 years	170	29.5%	30	17.6%
>65 years	10	1.7%	1	10.0%
Total	577	100%	164	28.4%

! Specific Performance Characteristics

Clinical Performance

Clinical specimens were collected from two multi-center investigational studies using throat ESwab specimens (flocked swab in Liquid Amies medium) from patients presenting with signs and symptoms of pharyngitis. One study enrolled consented subjects from whom a second prospective throat swab specimen was collected following the collection of a standard of care (SOC) throat swab. Another study tested specimens from subjects for which leftover excess standard of care (SOC) throat swab specimens were available. Across the two studies, the Xpert Xpress Strep A test was evaluated by 9 clinical sites from geographically diverse regions within the United States between December 2016 and March 2017.

Eight hundred and forty-four (844) specimens were initially enrolled in the two studies. Of these, 261 were excluded from the analysis of performance due to failure to comply with the inclusion criteria (19), reference culture procedural error (184), delay in reference culture inoculation (31), delay in shipment (26) or labeling error (1).

Among the 583 specimens included in the analysis of performance, 96.9 (565/583) were successful on the initial test and upon retest 99.0% (577/583) gave valid results.

The sensitivity, specificity, positive predictive value (PPV), and negative predictive value (NPV) of the Xpert Xpress Strep A were established relative to culture and latex agglutination for Strep A typing. The overall performance of the Xpert Xpress Strep test from both studies combined is presented in [Table 4](#). Results of the first study (second swab specimens) and the second study (SOC throat swab, i.e., first swab) are presented separately in [Table 5](#). Discordant results between Xpert Xpress Strep A and culture were investigated using an alternative PCR/bidirectional sequencing test, the results of which are footnoted in [Table 4](#) and [Table 5](#).

Table 4. Overall Performance of the Xpert Xpress Strep A vs. Reference Method (First and Second Swab Data Combined)

Reference Method				
	Strep A	Positive	Negative	Total
Xpert Xpress Strep A	Positive	138	26 ^a	164
	Negative	0	413	413
	Total	138	439	577 ^b
Sensitivity		100% (95% CI: 97.3-100)		
Specificity		94.1% (95% CI: 91.5-95.9)		



Reference Method	
PPV	84.1% (95% CI: 77.8-88.9)
NPV	100% (95% CI: 99.1-100)

- Results from alternative PCR with bidirectional sequencing: 21 of 26 were Strep A Positive; 4 of 26 were Strep A Negative; 1 of 26 samples was not tested.
- On initial testing, 18/583 specimens (3.1%) produced indeterminate results; 16/18 were retested, of which 12 produced valid results that were included in the analysis of performance for a final indeterminate rate of 6/583 (0.9%).

Table 5. Performance of the Xpert Xpress Strep A vs. Reference Method (Data for First and Second Swab)

	First Swab ^a		Second Swab ^b	
	N	% (95% CI)	N	% (95% CI)
Sensitivity	65/65	100% (94.4-100)	73/73	100% (95.0-100)
Specificity	244/253 ^c	96.4% (93.4-98.1)	169/186 ^d	90.9% (85.9-94.2)
NPV	244/244	100% (98.5-100)	169/169	100% (97.8-100)
PPV	65/74	87.8% (78.5-93.5)	73/90	81.1% (71.8-87.9)

- On initial testing, 9/321 specimens (2.8%) produced indeterminate results; 7/9 were retested, of which 6 produced valid results that were included in the analysis of performance for a final indeterminate rate of 3/321 (0.9%).
- On initial testing, 9/262 specimens (3.4%) produced indeterminate results; all 9 were retested, of which 6 produced valid results that were included in the analysis of performance for a final indeterminate rate of 3/262 (1.1%).
- Results from alternative PCR with bidirectional sequencing: 7 of 9 were Strep A Positive; 1 of 9 was Strep A Negative; 1 of 9 samples was not tested.
- Results from alternative PCR with bidirectional sequencing: 14 of 17 were Strep A Positive; 3 of 17 were Strep A Negative.

Analytical Performance

Analytical Sensitivity (Limit of Detection)

Studies were performed to determine the analytical sensitivity or Limit of Detection (LoD) of the Xpert Xpress Strep A using the ESwab collection kit (Copan P/N 480CE or 480C referred to in Section 8 as the “ESwab”). The limit of detection is the lowest concentration of sample (reported as CFU/mL in ESwab transport medium or CFU/test) that can be reproducibly distinguished from negative samples 95% of the time, or the lowest concentration of organisms at which 19 of 20 replicates were positive. This study determined the lowest concentration of *Streptococcus pyogenes* cells diluted into pooled clinical throat swab matrix that can be detected using the Xpert Xpress Strep A.

The analytical sensitivity of the Xpert Xpress Strep A was performed using two lots of reagents tested across



three testing days with two *Streptococcus pyogenes* strains: ATCC BAA-946 and ATCC 19615.

The claimed LoD for each Strep A strain tested is summarized in [Table 6](#).

Table 6. Strep A LoD

Strep A Strain	emm type	LoD (CFU/mL in ESwab transport medium)	LoD (CFU/test)
ATCC BAA-946	6	9	3
ATCC 19615	80	18	6

Analytical Reactivity (Inclusivity)

Twenty-four *Streptococcus pyogenes* strains were tested at 3X LoD using the Xpert Xpress Strep A in replicates of three. The strains tested included representative isolates of *emm* types 1, 3, 4, 6, 11, 12, 18, 22, 25, 27, 38, 75, 77, 89, 94, 95. The list of strains tested in ESwab medium containing simulated throat swab matrix is shown in [Table 7](#). All 24 strains were correctly reported as **Strep A DETECTED** with the Xpert Xpress Strep A.

Table 7. Analytical Reactivity (Inclusivity) of Xpert Xpress Strep A

Strep A Strain ID	emm type	Strain
ATCC 12202	1	NCTC 8370
ATCC 12344	1	T1
ATCC 700294	1	SF370
ATCC 12383	3	D58X
ATCC 12384	3	C203
ATCC 12385	4	J17A4
ATCC 12203	6	NCTC 8709
ATCC 12352	11	T11
ATCC BAA-1065	12	MGAS 2096
ATCC BAA-1315	12	MGAS9429
ATCC 12357	18	J17C
ATCC 10403	22	T22
ATCC 12204	25	A25
ATCC 8135	27	T27
ATCC 12365	38	C107
ATCC 12370	38	C94
ATCC 700497	75	CDC-SS-1147
ATCC 700499	77	CDC-SS-1149
ATCC 700949	89	CDC-SS-1397
ATCC BAA-355	94	N/A
ATCC BAA-356	95	N/A
ATCC 14289	M protein deficient <i>S.pyogenes</i>	C203 S



Strep A Strain ID	emm type	Strain
ATCC 49399	emm type not available	QC A62
ATCC 51339	emm type not available	1805

Analytical Specificity (Exclusivity)

The analytical specificity of the Xpert Xpress Strep A was evaluated by testing a panel of 70 potentially cross-reactive microorganisms, including species that are phylogenetically related to *Streptococcus pyogenes* and members of the throat commensal microflora (e.g., other bacteria, viruses, and yeast). The 70 organisms tested were identified as either Gram-positive (27), Gram-negative (33), or Gram-indeterminate (3), yeast (1), and viruses (6). *Streptococcus* Group B, *Streptococcus* Group C, and *Streptococcus* Group G strains were also included in this study. All strains were tested in triplicate in ESwab transport medium containing simulated throat swab matrix at $\geq 10^6$ CFU/mL for bacteria and yeast and $\geq 10^5$ TCID₅₀/mL for viruses. All three replicates of all 70 organisms were reported as **Strep A NOT DETECTED** by the Xpert Xpress Strep A (Table 8). The analytical specificity of the Xpert Xpress Strep A was 100%.

Table 8. Analytical Specificity of Xpert Xpress Strep A

Organism	Results
<i>Acinetobacter baumannii</i>	Strep A NOT DETECTED
<i>Arcanobacterium haemolyticum</i>	Strep A NOT DETECTED
Adenovirus, Type 1	Strep A NOT DETECTED
Adenovirus, Type 7	Strep A NOT DETECTED
<i>Bacillus cereus</i>	Strep A NOT DETECTED
<i>Bordetella bronchiseptica</i>	Strep A NOT DETECTED
<i>Bordetella parapertussis</i>	Strep A NOT DETECTED
<i>Bordetella pertussis</i>	Strep A NOT DETECTED
<i>Burkholderia cepacia</i>	Strep A NOT DETECTED
<i>Campylobacter rectus</i>	Strep A NOT DETECTED
<i>Candida albicans</i>	Strep A NOT DETECTED
<i>Corynebacterium diphtheriae</i>	Strep A NOT DETECTED
<i>Corynebacterium pseudodiphtheriticum</i>	Strep A NOT DETECTED
Cytomegalovirus AD-169	Strep A NOT DETECTED
<i>Enterococcus faecalis</i>	Strep A NOT DETECTED
<i>Enterococcus faecium</i>	Strep A NOT DETECTED
Epstein-Barr Virus 4	Strep A NOT DETECTED
<i>Escherichia coli</i>	Strep A NOT DETECTED
<i>Fusobacterium necrophorum</i>	Strep A NOT DETECTED
<i>Haemophilus influenzae</i> type A	Strep A NOT DETECTED
<i>Haemophilus parahaemolyticus</i>	Strep A NOT DETECTED
<i>Haemophilus parainfluenzae</i>	Strep A NOT DETECTED
Hepatitis B Virus	Strep A NOT DETECTED
Herpes Simplex Virus	Strep A NOT DETECTED
<i>Klebsiella pneumoniae</i>	Strep A NOT DETECTED



Organism	Results
<i>Lactobacillus acidophilus</i>	Strep A NOT DETECTED
<i>Lactococcus lactis</i> subsp. <i>lactis</i>	Strep A NOT DETECTED
<i>Legionella jordanis</i>	Strep A NOT DETECTED
<i>Legionella micdadei</i>	Strep A NOT DETECTED
<i>Legionella pneumophila</i>	Strep A NOT DETECTED
<i>Listeria monocytogenes</i>	Strep A NOT DETECTED
<i>Moraxella catarrhalis</i> (two strains)	Strep A NOT DETECTED
<i>Moraxella lacunata</i>	Strep A NOT DETECTED
<i>Mycoplasma pneumoniae</i>	Strep A NOT DETECTED
<i>Neisseria gonorrhoeae</i>	Strep A NOT DETECTED
<i>Neisseria lactamica</i>	Strep A NOT DETECTED
<i>Neisseria meningitidis</i>	Strep A NOT DETECTED
<i>Neisseria mucosa</i>	Strep A NOT DETECTED
<i>Neisseria sicca</i>	Strep A NOT DETECTED
<i>Neisseria subflava</i>	Strep A NOT DETECTED
<i>Peptostreptococcus micros</i>	Strep A NOT DETECTED
<i>Prevotella (Bacteroides) oralis</i>	Strep A NOT DETECTED
<i>Proteus mirabilis</i>	Strep A NOT DETECTED
<i>Proteus vulgaris</i>	Strep A NOT DETECTED
<i>Pseudomonas aeruginosa</i>	Strep A NOT DETECTED
<i>Pseudomonas fluorescens</i>	Strep A NOT DETECTED
<i>Serratia marcescens</i>	Strep A NOT DETECTED
<i>Staphylococcus aureus</i>	Strep A NOT DETECTED
<i>Staphylococcus epidermidis</i>	Strep A NOT DETECTED
<i>Staphylococcus haemolyticus</i>	Strep A NOT DETECTED
<i>Stenotrophomonas maltophilia</i>	Strep A NOT DETECTED
<i>Streptococcus agalactiae</i>	Strep A NOT DETECTED
<i>Streptococcus anginosus</i>	Strep A NOT DETECTED
<i>Streptococcus bovis</i>	Strep A NOT DETECTED
<i>Streptococcus canis</i>	Strep A NOT DETECTED
<i>Streptococcus constellatus</i>	Strep A NOT DETECTED
<i>Streptococcus dysgalactiae</i>	Strep A NOT DETECTED
<i>Streptococcus equi</i>	Strep A NOT DETECTED
<i>Streptococcus gallolyticus</i>	Strep A NOT DETECTED
<i>Streptococcus intermedius</i>	Strep A NOT DETECTED
<i>Streptococcus mitis</i>	Strep A NOT DETECTED
<i>Streptococcus mutans</i>	Strep A NOT DETECTED
<i>Streptococcus oralis</i>	Strep A NOT DETECTED
<i>Streptococcus pneumoniae</i>	Strep A NOT DETECTED
<i>Streptococcus salivarius</i>	Strep A NOT DETECTED



Organism	Results
<i>Streptococcus sanguinus</i>	Strep A NOT DETECTED
<i>Treponema denticola</i>	Strep A NOT DETECTED
<i>Veillonella parvula</i>	Strep A NOT DETECTED
<i>Yersinia enterocolitica</i>	Strep A NOT DETECTED

Carry-over Contamination

A study was conducted to demonstrate that single-use, self-contained GeneXpert cartridges prevent specimen and amplicon carry-over contamination from very high titer positive samples (*S. pyogenes*) into successively run negative samples when processed in the same GeneXpert module. The study consisted of a negative sample processed in the same GeneXpert module immediately after processing a very high titer positive sample at a concentration $\geq 1 \times 10^6$ CFU/mL in ESwab transport medium containing simulated throat swab matrix. The testing scheme was repeated 40 times between 2 GeneXpert instruments (one module per instrument) for a total of 41 runs per instrument (20 high positive samples per instrument and 21 negative samples per instrument). There was no evidence of any carry-over contamination. All 42 negative samples were correctly reported as **Strep A NOT DETECTED**. All 40 positive samples were correctly reported as **Strep A DETECTED**.

Potentially Interfering Substances

Ten potentially interfering substances that may be present in clinical throat specimens with the potential to interfere with the performance of the Xpert Xpress Strep A were evaluated. The potentially interfering substances included blood, mucus, human saliva, sugar-containing cold and flu remedies, cough medicine, antiseptic, salt-modifying remedies, pH-modifying remedies, antacids, and foods or drinks that increase salivary viscosity. The substances, active ingredients, and concentrations tested are listed in [Table 9](#). Medically and/or physiologically relevant concentrations of potential interferents were tested in simulated throat swab matrix in the presence and absence of Strep A at 3X LoD.

There was no test interference in the presence of the substances at the concentrations tested in this study. All positive and negative samples were correctly identified using the Xpert Xpress Strep A.

Table 9. Potential Interfering Substances Tested

Substance/Class	Description/Active Ingredient	Concentration Tested
Saliva	100% Human Saliva	6.5% (v/v)
Mucin	Bound sialic acid, 0.5-1.5%	2.5% (w/v)
Blood	Whole human blood	5.0% (v/v)
Antiseptic	0.092% Eucalyptol, 0.042% menthol, 0.060% methyl salicylate, 0.064% thymol	6.5% (v/v) ^a
Cough Medicine	Dextromethorphan HBr USP 10 mg, Guaifenesin USP 200 mg	5 mg/mL
Sugar-containing cold and flu remedies	Acetaminophen 650 mg, Dextromethorphan HBr 20 mg, Doxylamine Succinate 12.5 mg, Phenylephrine HCl 10 mg	6.5% (v/v)
Salt-modifying remedies	Sodium Chloride (0.65%)	6.5% (v/v)



Substance/Class	Description/Active Ingredient	Concentration Tested
Foods/drinks that increase salivary viscosity	Milk	6.5% (v/v)
pH Modifying Remedies	100% Orange juice	6.5% (v/v)
Antacids	Aluminum Hydroxide 400 mg (equivalent to dried gel, USP) – antacid, Magnesium Hydroxide 400 mg – antacid, Simethicone 40 mg – antigas	6.5% (v/v)

- a. Although all samples were reported appropriately as positive or negative, reduced fluorescent signal for the *S. pyogenes* target was observed in the presence of antiseptic mouthwash at 6.5% v/v.

Microbial Interference

An interfering microorganism study was performed to assess the inhibitory effects of commensal microorganisms in throat swab samples on the performance of the Xpert Xpress Strep A. Twenty-seven microorganisms were tested for potential interference with Strep A detection (Table 10). The microorganisms were tested at $\geq 10^6$ CFU/mL in the presence of Strep A at 3X LoD concentration in ESwab medium containing simulated throat swab matrix. The results showed that the presence of the tested microorganisms did not interfere with the detection of Strep A target DNA.

Table 10. Commensal Microorganisms Tested

Organism		
<i>Acinetobacter baumannii</i>	<i>Staphylococcus epidermidis</i>	<i>Streptococcus intermedius</i>
<i>Candida albicans</i>	<i>Streptococcus agalactiae</i>	<i>Streptococcus mitis</i>
<i>Enterococcus faecalis</i>	<i>Streptococcus anginosus</i>	<i>Streptococcus mutans</i>
<i>Fusobacterium necrophorum</i>	<i>Streptococcus bovis</i>	<i>Streptococcus oralis</i>
<i>Haemophilus influenzae</i> type A	<i>Streptococcus canis</i>	<i>Streptococcus pneumoniae</i>
<i>Lactobacillus acidophilus</i>	<i>Streptococcus constellatus</i>	<i>Streptococcus salivarius</i>
<i>Neisseria lactamica</i> ^a	<i>Streptococcus dysgalactiae</i>	<i>Streptococcus sanguinus</i>
<i>Peptostreptococcus micros</i>	<i>Streptococcus equi</i>	<i>Treponema denticola</i>
<i>Prevotella (Bacteroides) oralis</i>	<i>Streptococcus gallolyticus</i>	<i>Veillonella parvula</i>

- a. Although all samples were reported appropriately as positive, reduced fluorescent signal was observed for the *S. pyogenes* target in the presence of high concentrations of *N. lactamica*.

Reproducibility

A three member reproducibility panel with varying concentrations of *Streptococcus pyogenes* was tested 4 times per day on six different days by two different operators at three sites (3 specimens x 4 times/day x 6 days x 2 operators x 3 sites). Three lots of Xpert Xpress Strep A cartridges were used, with each representing two days of testing. The samples were prepared in simulated throat swab matrix at the different concentration levels and are presented in Table 11. When the study was initially performed, there was an unexpectedly high rate of indeterminate results (47/432 = 10.8%), although no false positive or false negative results were observed. Upon retest of the indeterminate samples, the indeterminate rate was reduced to 2.8% (12/432). Despite the high indeterminate rate, the analytical performance of the test was acceptable in the initial reproducibility study; the percent concordance met the acceptance criteria for the negative, Strep A low positive, and Strep A moderate positive samples at 100% (144/144), 100% (138/138), and 100% (138/138), respectively. Following an investigation, the study was repeated with fresh panels and different lots of reagents. Results of the repeat reproducibility study are summarized in Table 12 by study site/operator.



Table 11. Reproducibility Panel

Strain	Panel Member
Not applicable	Negative
ATCC BAA-946 (<i>Streptococcus pyogenes</i>)	Low Positive (~1X LoD)
ATCC BAA-946 (<i>Streptococcus pyogenes</i>)	Moderate Positive (~3X LoD)

Table 12. Summary of Reproducibility Results: % Agreement by Study Site/Operator

Sample	Site 1			Site 2			Site 3			% Total Agreement by Sample ^a
	Op 1	Op 2	Site	Op 1	Op 2	Site	Op 1	Op 2	Site	
Neg	100% (24/24)	100% (24/24)	100% (48/48)	100% (24/24)	100% (24/24)	100% (48/48)	100% (24/24)	100% (24/24)	100% (48/48)	100% (144/144)
Low Pos	92% (22/24)	100% (24/24)	96% (46/48)	100% (24/24)	100% (24/24)	100% (48/48)	100% (24/24)	100% (24/24)	100% (48/48)	98.6% (142/144)
Mod Pos	100% (24/24)	100% (24/24)	100% (48/48)	100% (24/24)	100% (24/24)	100% (48/48)	100% (24/24)	100% (24/24)	100% (48/48)	100% (144/144)

a. Eleven (11) indeterminate results were obtained over the course of the repeat study for an initial indeterminate rate of 2.5% (11/432). In all cases, the expected results were obtained upon retesting.

The reproducibility of the Xpert Xpress Strep A was also evaluated in terms of the fluorescence signal expressed in Ct values for each target detected. The mean, standard deviation (SD), and coefficient of variation (CV) between-sites, between-lots, between-days, between-operators and within-test for each panel member are presented in [Table 13](#).

Table 13. Summary of Reproducibility Data

Sample	Assay Channel (Analyte)	N ^a	Mean Ct	Between-Site		Between-Lot		Between-Day		Between-Operator		Within-Test		Total	
				SD	CV	SD	CV	SD	CV	SD	CV	SD	CV	SD	CV
Neg	SPC	144	34.7	0	0	1.9	5.3	0.3	1.0	0	0	1.3	3.7	2.3	6.6
Strep A Low Pos	SA	142	37.8	0.2	0.6	0	0	0.1	0.4	0.1	0.2	1.0	2.7	1.1	2.8
Strep A Mod Pos	SA	144	36.5	0	0	0.3	0.8	0	0	0.1	0.3	0.9	2.3	0.9	2.5

a. Results with non-zero Ct values out of 144.

? Appendix

Bibliography

1. Centers for Disease Control and Prevention, National Center for Immunization and Respiratory Diseases, Division of Bacterial Diseases. ABCs Report: group A Streptococcus, 2003. December 27, 2004. Available at: <https://www.cdc.gov/abcs/reports-findings/survreports/gas03.html>. Accessed May 3, 2017.
2. Centers for Disease Control and Prevention, National Center for Immunization and Respiratory Diseases, Division of Bacterial Diseases. Scarlet Fever: A Group A Streptococcal Infection. January 20, 2015. Available at: <http://www.cdc.gov/features/scarletfever/>. Accessed October, 22, 2015.
3. Centers for Disease Control and Prevention. Biosafety in Microbiological and Biomedical laboratories (refer to latest edition). <http://www.cdc.gov/biosafety/publications/>
4. Clinical and Laboratory Standards Institute. Protection of Laboratory Workers from Occupationally Acquired Infections; Approved Guideline. Document M29 (refer to latest edition).
5. REGULATION (EC) No 1272/2008 OF THE EUROPEAN PARLIAMENT AND OF THE COUNCIL of 16 December 2008 on the classification labeling and packaging of substances and mixtures amending and repealing, List of Precautionary Statements, Directives 67/548/EEC and 1999/45/EC (amending Regulation (EC) No 1907/2007).
6. Occupational Safety and Health Standards, Hazard Communication, Toxic and Hazard Substances (March 26, 2012) (29 C.F.R., pt. 1910, subpt. Z).

Cepheid Headquarters Locations

Corporate Headquarters

Cepheid
904 Caribbean Drive
Sunnyvale, CA 94089
USA

Telephone: + 1 408 541 4191
Fax: + 1 408 541 4192
www.cepheid.com

European Headquarters

Cepheid Europe SAS



Vira Solelh
81470 Maurens-Scopont
France

Telephone: + 33 563 825 300
Fax: + 33 563 825 301
www.cepheidinternational.com

Technical Assistance

Before contacting Cepheid Technical Support, collect the following information:

- Product name
- Lot number
- Serial number of the instrument
- Error messages (if any)
- Software version and, if applicable, Computer Service Tag number

United States Technical Support







Telephone: + 1 888 838 3222
Email: techsupport@cepheid.com

France Technical Support

Telephone: + 33 563 825 319
Email: support@cepheideurope.com

Contact information for all Cepheid Technical Support offices is available on our website: www.cepheid.com/en/support/contact-us.

Table of Symbols

Symbol	Meaning
	Catalog number
	<i>In vitro</i> diagnostic medical device
	Do not reuse
	Batch code
	Consult instructions for use
	Caution
	Manufacturer

Symbol	Meaning
	Country of manufacture
	Contains sufficient for <i>n</i> tests
CONTROL	Control
	Expiration date
	Temperature limitation
	Biological risks
	Warning
R_xonly	For prescription use only



Cepheid

904 Caribbean Drive

Sunnyvale, CA 94089

USA

Telephone: + 1 408 541 4191

Fax: + 1 408 541 4192

www.cepheid.com

IVD

Revision History

Description of Changes: 303-0929 Rev. A to B

Purpose: Removed "CLIA Complexity: Moderate"

Section	Description of Change
Cover	Removed "CLIA Complexity: Moderate"
Materials Provided	Removed "CLIA Complexity: Moderate"

